

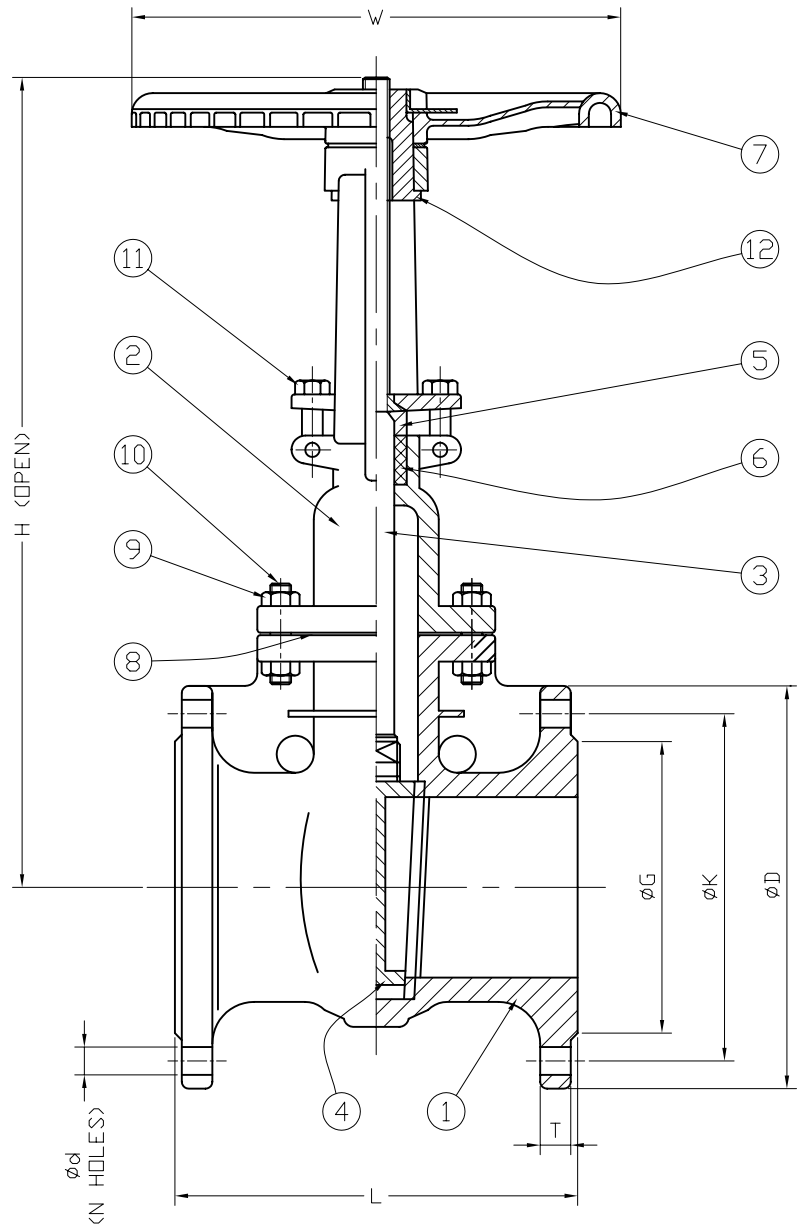

# De Programme :  
 Valve(s) :  
 Temp. de Machinage. :



	SIZE	W	L	H	øD	øK	øG	T	ød	N
IN	2"	6.30	7.00	14.17	6.00	4.70	3.60	0.59	0.79	4
mm	50.0	160.0	178.0	360.0	152.4	119.3	91.4	15.0	20.0	
IN	2-1/2"	7.87	7.50	15.35	7.00	5.50	5.00	0.71	0.79	4
mm	65.0	200.0	190.5	390.0	177.8	139.7	127.0	18.0	20.0	
IN	3"	7.87	8.00	18.19	7.50	6.00	5.50	0.79	0.79	4
mm	80.0	200.0	203.0	462.0	190.5	152.4	139.7	20.0	20.0	
IN	4"	9.84	9.00	21.25	9.00	7.50	6.19	0.91	0.79	8
mm	100.0	250.0	229.0	540.0	228.6	190.5	157.2	23.0	20.0	
IN	6"	12.60	10.50	28.46	11.00	9.50	8.50	1.10	0.91	8
mm	150.0	320.0	267.0	723.0	279.4	241.3	215.9	28.0	23.0	
IN	8"	14.96	11.50	36.61	13.50	11.81	10.59	1.10	0.91	12
mm	200.0	380.0	292.0	930.0	342.9	300.0	269.0	28.0	23.0	
IN	10"	17.71	13.00	47.25	16.00	14.30	12.80	1.18	1.00	12
mm	250.0	450.0	330.0	1200.0	406.0	363.0	325.0	30.0	25.4	
IN	12"	17.71	14.00	53.15	19.00	17.00	15.00	1.30	1.00	12
mm	300.0	450.0	356.0	1350.0	482.6	431.8	381.0	33.0	25.4	

NOTE: ALL DIMENSIONS ARE IN INCHES & MILLIMETERS  
 FACE TO FACE DIMENSIONS: ANSI B16.10  
 SHELL WALL THICKNESS: ANSI B16.34 MSS SP-42  
 END FLANGE DIMENSIONS: ANSI B16.5

13	-	--	--	
12	1	YOKE SLEEVE	BRONZE	
11	SET	GLAND BOLT	304 STAINLESS STEEL	
10	SET	BONNET STUD	ASTM A193 Gr. B8M	
9	SET	BONNET NUT	ASTM A194 Gr. 8M	
8	1	GASKET	316 Sst. + GRAFOIL	
7	1	HANDWHEEL	FCD45	--
6	SET	GLAND PACKING	GRAPHITE	--
5	1	GLAND	ASTM A351 Gr. CF8M	--
4	1	DISC	ASTM A351 Gr. CF8M	--
3	1	STEM	316 STAINLESS STEEL	
2	1	BONNET	ASTM A351 Gr. CF8M	
1	1	BODY	ASTM A351 Gr. CF8M	
ITEM	QTY	PART DESCRIPTION	MATERIAL SPECIFICATION	REFERENCE / NOTES

F						
E						
D				TITLE 2"-12" FIG. N-136B FLANGED GATE VALVES		
C				- STAINLESS STEEL, ANSI CLASS 150		
B				DRAWN BY: FX	DATE: 12/29/2005	SCALE: NTS
A	----	-	----	APPROVED BY: MDA	DATE: 12/30/2005	SHEET: 1 OF: 1
LET	REVISION	BY	DATE	MAT'L	DWG No.	REV
A <sub>P</sub> D	C <sub>H</sub> K			CAST Sst.	TL2481B	—